

Total specification of Steel structure

Specification Noted: The project was designed based on China's current construction-related norms and protocols. Owners are requested to bring this design to the architectural design department of the local government for auditions. Only after being vetted and approved, before the construction,

A. design consignment

- Based on China's current norms and protocols:
 - <Code for design of steel structures>(GB50017-2003)
 - <Code for design of steel structures>(GB50017-2003)
 - <Technical code for design of cold-formed thin-wall steel structures>(GB50018-2002)
 - <Steel Structure Construction Quality Acceptance of norms>(GB50205-2001)
 - <Unified standard for design of building structures>(GBJ88-84)
 - <Code for seismic design of buildings>(GB50011-2001)
 - <High-strength bolts connecting of steel structure design, construction and acceptance of order>(JGJ82-91)
 - <carbon construction steel>(GB/T700-88)
 - <Specification for welding of steel structure buildings>(JGJ81-2002)
 - <Code for design of concrete structures>(GB50010-2002)
 - <Code for design of building foundations>(GB50007-2002)

B. The designed elevation of this project is: ± 0.000, the relative positions determined at the site.

C. summary of Structure design:

- The project developed by using of Tongji University's 3D3S Steel structure calculation software for structural calculations.
- The safety rating of this project is Grade 2, and the reasonable life span of this project is 25 years.
- The basis of a separate design
 - Roof Dead load: 0.2 KN/m²
 - Wind load: 0.4 KN/m²
 - Snow load: 0.6 KN/m²

D. Material

- Main components' material of Steel frame beam, pillar is Q345B. Its material chemical composition and mechanical properties should be in line with national standards. <carbon construction steel> (GB/T700-88)
Purification use cold-formed steel with quality standard<general Cold forming sectional steel>(GB6723-86).
- welding rod:
 - Q235B steel weld by hand adapt E43XX style welding rod,the function<carbon steel covered electrode>(GB/T5117-95). Adapt automatic or semi-automatic;use <Welded wires>(GB1300-77) with H08 or H08A Wire with the manganese-based or high-manganese-based flux.
 - Q235B steel weld by hand adapt E50XX style welding rod. Adapt automatic or semi-automatic;use<Welded wires>(GB1300-77) with H08MnA wire with the manganese-based or high-manganese-based flux.

3.black rough bolt,nuts and washers adapt(GB700-88) with Q235 steel,the heat treatment,Productive and technical requirements will be to in line with(GB9790-86),(GB41-86),(GB95-85).

4.The 10.9 grade high-strength bolt adopt the big orthohexagonal bolt,its function will consistent with national standard <Alloy structure steel-Technical requirements>(GB3077-82) with 20MnTiB steel or 40B steel or with consistent with national standard<High-strength steel with large hexagon head bolts, large hexagon head nuts, washers and technological conditions>(GB1231-91)with 35VB steel,the pre-pull of high-strength bolt is:M16:P=100KN M20:P=155KN.

E. Manufacture of Structure:

- Steel structure should be in strict accordance with<GB50205-01>.All components is crucial to enlarge;1:sample to check,After size correct,then progressive Blanking,will be pre-assembly inspection before delivery.Girders production arch camber should be appropriate to reduce the actual beam deflection.
- Steel processing should be carried out before the correction, to make it straight.
- welding requirements:
 - Component commissure plate and column, the connections of end-plate and beam department weld and column flange.The Butt Weld of ventral shield should be adopted through the complete fusion weld and quality should be consistent with the 2grade weld quality requirements.Others as per 3grade welded quality demand.
 - When welding,Should choose a reasonable welding sequence to reduce the steel produced in the welding stress and welding distortion, or Preheat hammering and overall tempering and other methods to achieve the same purpose.
 - When welding of frame beam,pilla. The flange and the ventral shield that the location of seams staggered more than 250mm.
 - Where the drawing do not indicate the leg of a fillet weld. The foot:岩槽 of its size Hf welding thin pieces of equal thickness, the weld length equal to the length of component overlap, and are full welding.

F. Installation of structure:

- Before with pre-installation component to conduct a comprehensive inspection,such as the qty of component,length,perpendicularity, Joint installed between the bolt hole size with the design requirements.
- When lifting,should take appropriate measures to prevent excessive bending deformation.
- After lifting the structure in place,Should be fastened/timely support and other components connected to guarantee the stability of components.
- All of the structure lifting must be in the lower part of the structure in place, correction and fastened support component,then would be required.
- Construction requirements of High-strength bolt:
 - High-strength bolt hole should be adapted drilled hole.
 - before installation,match with the bolts and nuts,and nut with a small amount of mineral oil.
 - In the high-strength bolts connecting the framework of the contact elements to deal with the use of sandblasting, anti-slip coefficient $U \geq 0.45$, may not paint or defaced.

G. Descaling and paint of steel structure:

- Before coating of the components,must deal with surface shot blasting and derusting,the derusting grade is Sa2.5.
- The first painting with red lead paint, surface is alkyd ready mixed paint.
- Steel structure in the use of process should be conducted every three years paint maintenance, and timely maintenance of local paint.
- This note as a general steel plant,if the production of corrosive gases or high temperature and humidity should be dealt with separately.

H. If there is anything else not in this specification,please be strict In accordance with current national norms and protocols relating to the construction.



Hangzhou Putian Steel Structure Co.,Ltd

Item	Total specification of Steel structure	Project No.	PT12W100	Category	Proposal
				Page	01
				Version	03
Project Name	450m2 project	比 9#		Date	10.09.28

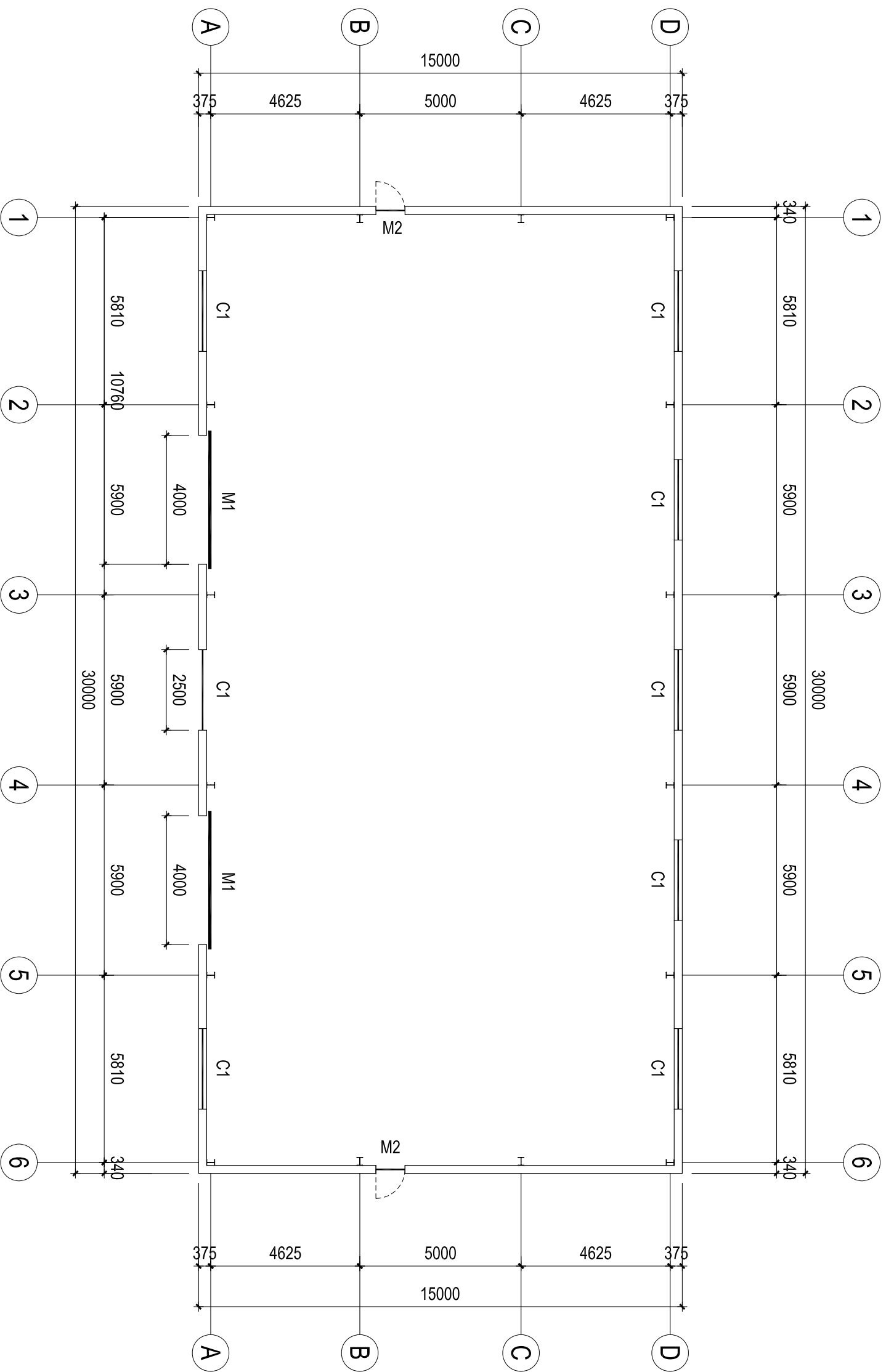

Layout for the Ground plan

- M1:4000*4000 Electrical Rolling shutter door
- M2:900*2000 Steel security window
- C1:2500*1200 Aluminum alloy window



Hangzhou Putian Steel Structure Co., Ltd

Item	Layout for the Ground plan	Project No.	PTX21100	Category	Proposal
Project Name	450m2 project	Page	02	Version	03
比例	200:1	Date	10.09.28		

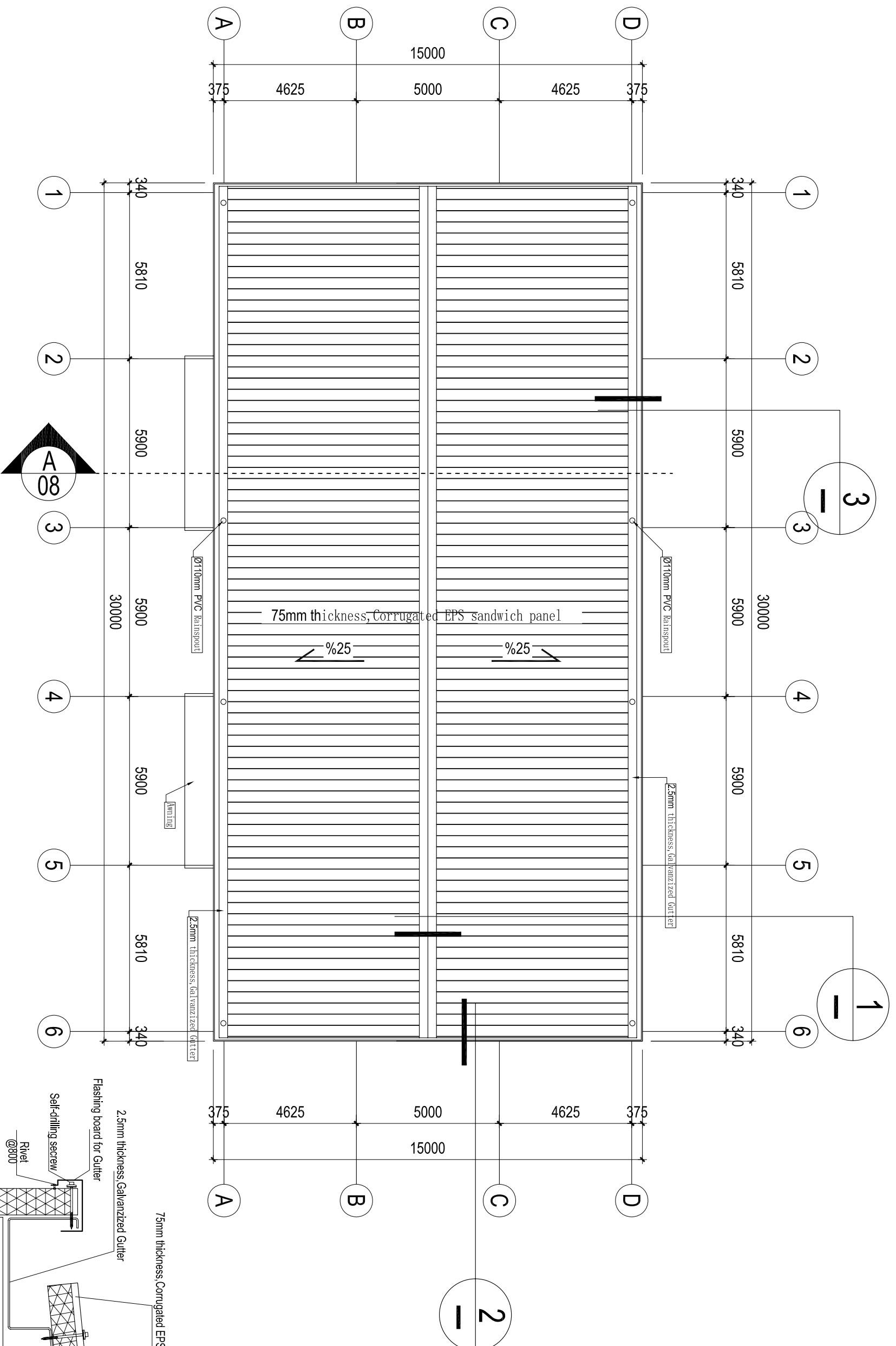

Layout for roof plan

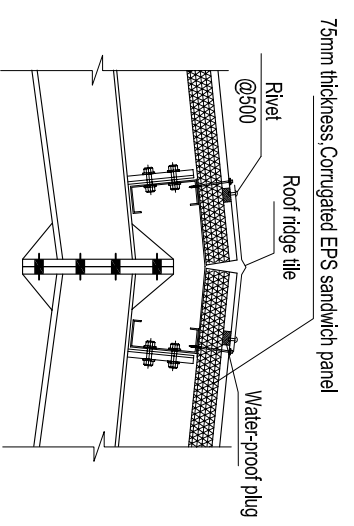

1

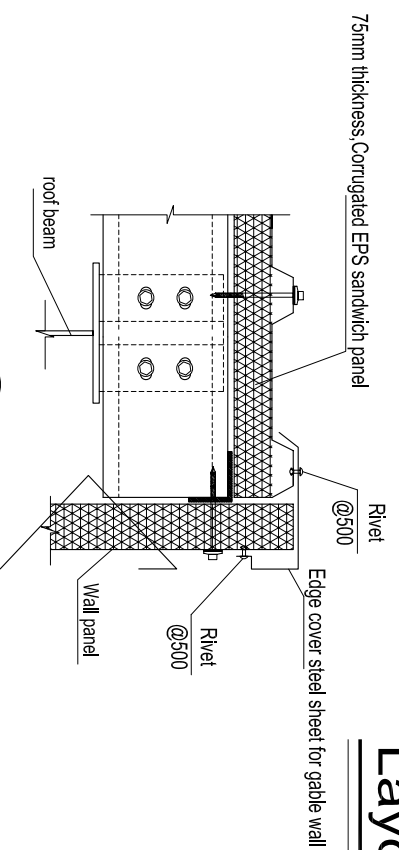

2

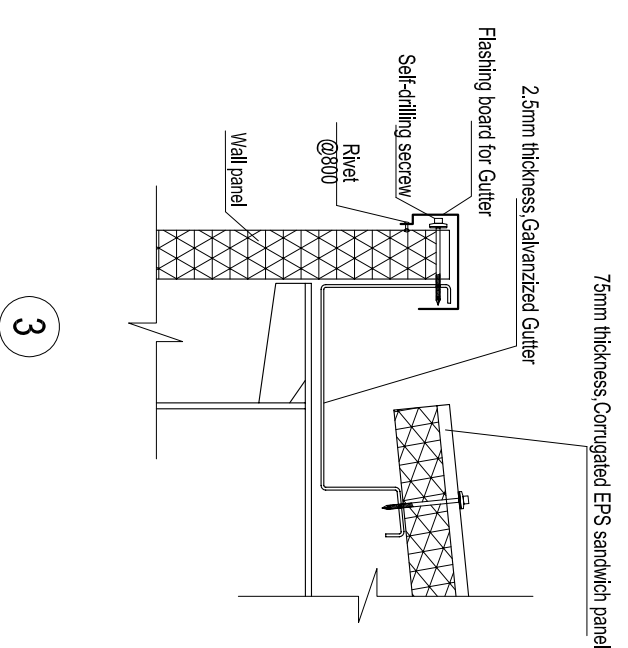

3

		Hangzhou Putian Steel Structure Co., Ltd	
Item	Layout for roof plan	Project No.	PTX201100
Category	Proposal	Page	03
Version	03	Date	10.09.28
Project Name	450m2 project	Fig. No.	200-1

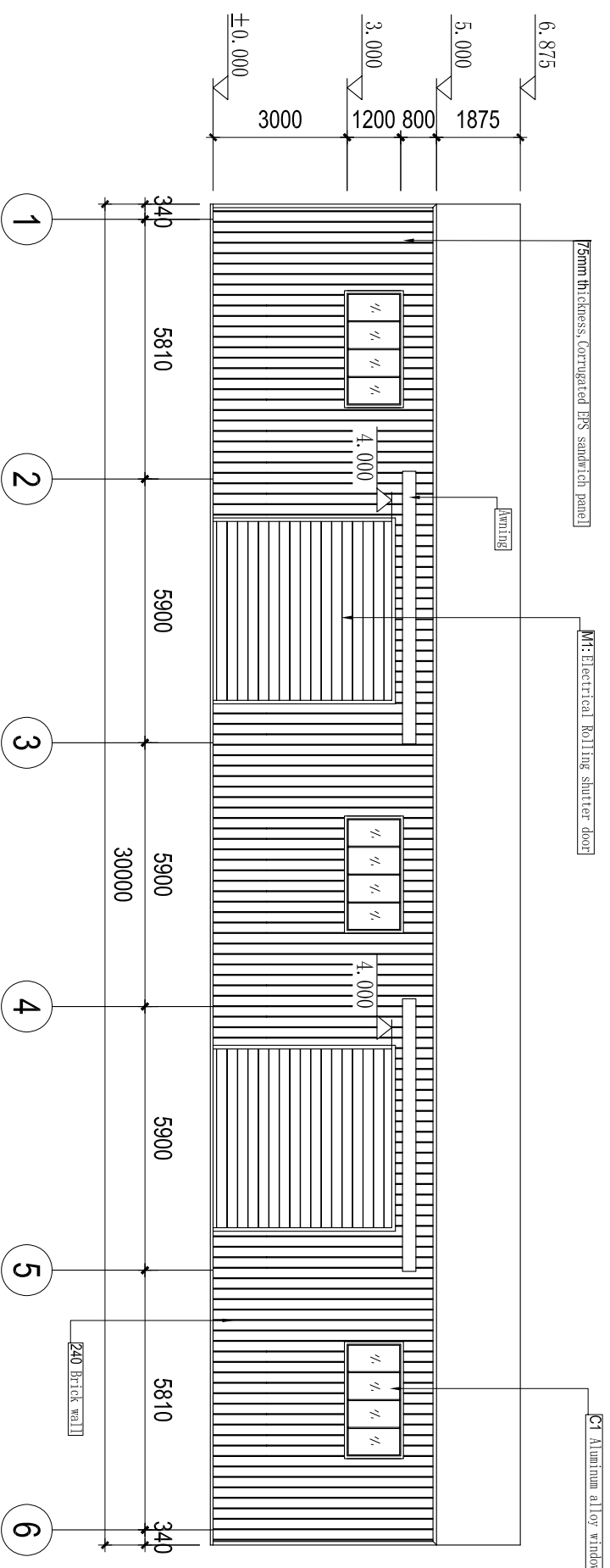

Elevation for A axis

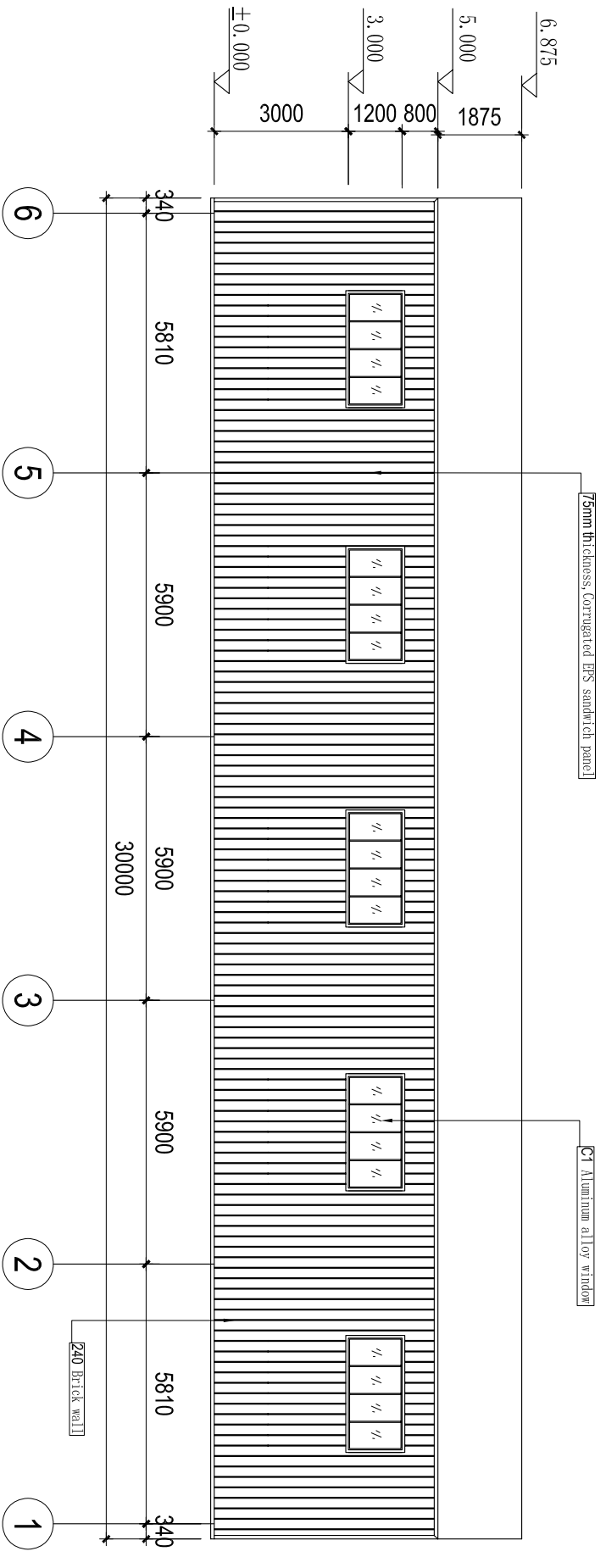

Elevation for D axis

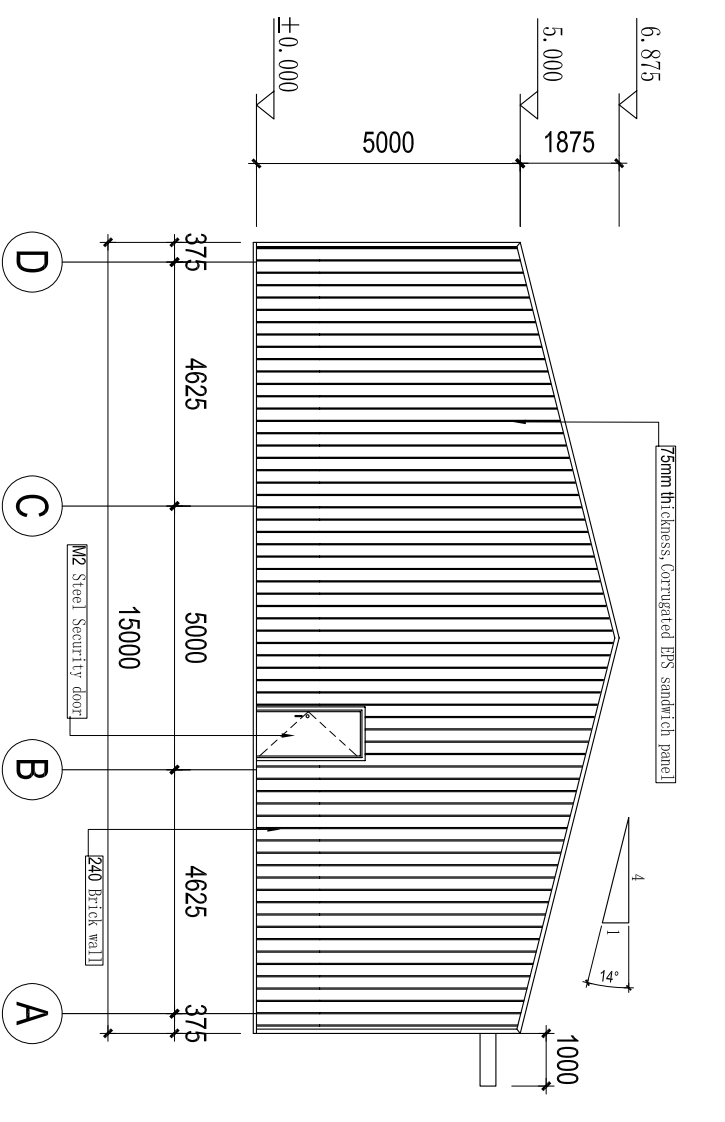

Elevation for 1 axis

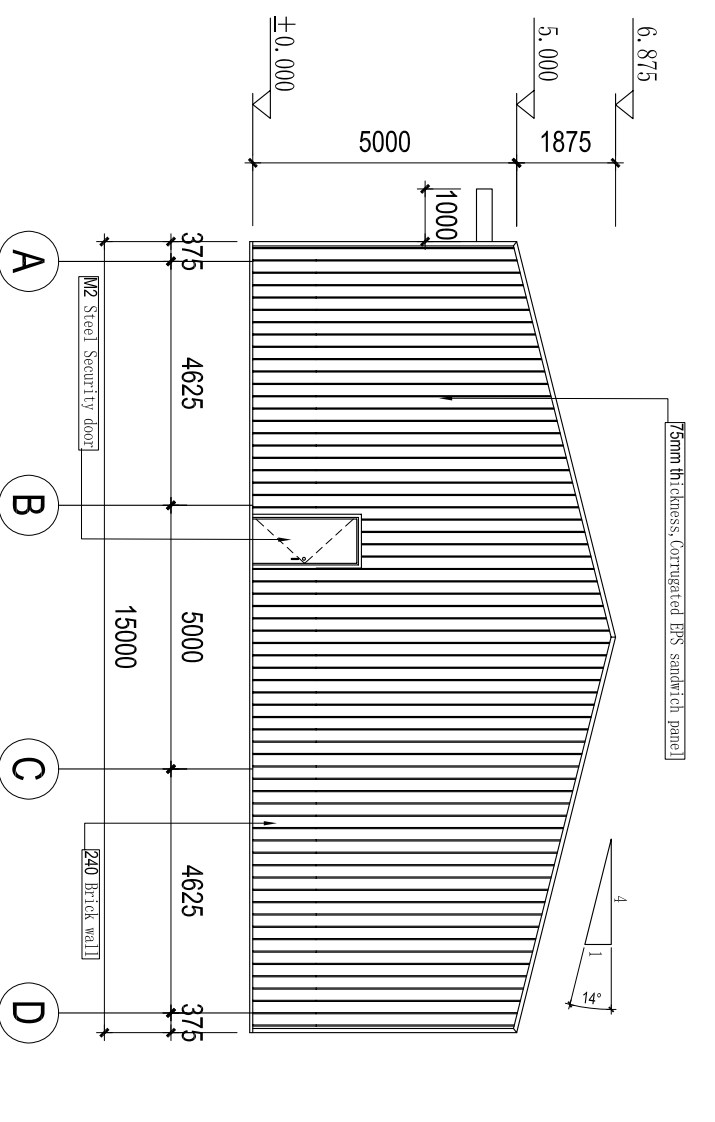

Elevation for 6 axis

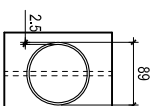
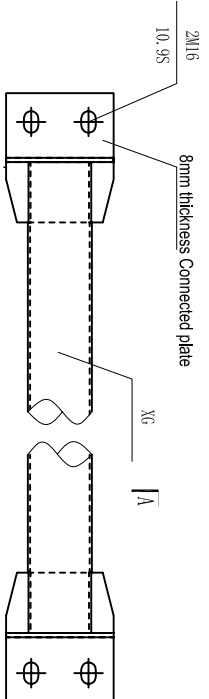

A-A

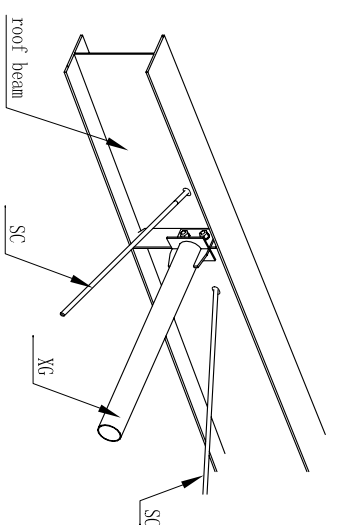
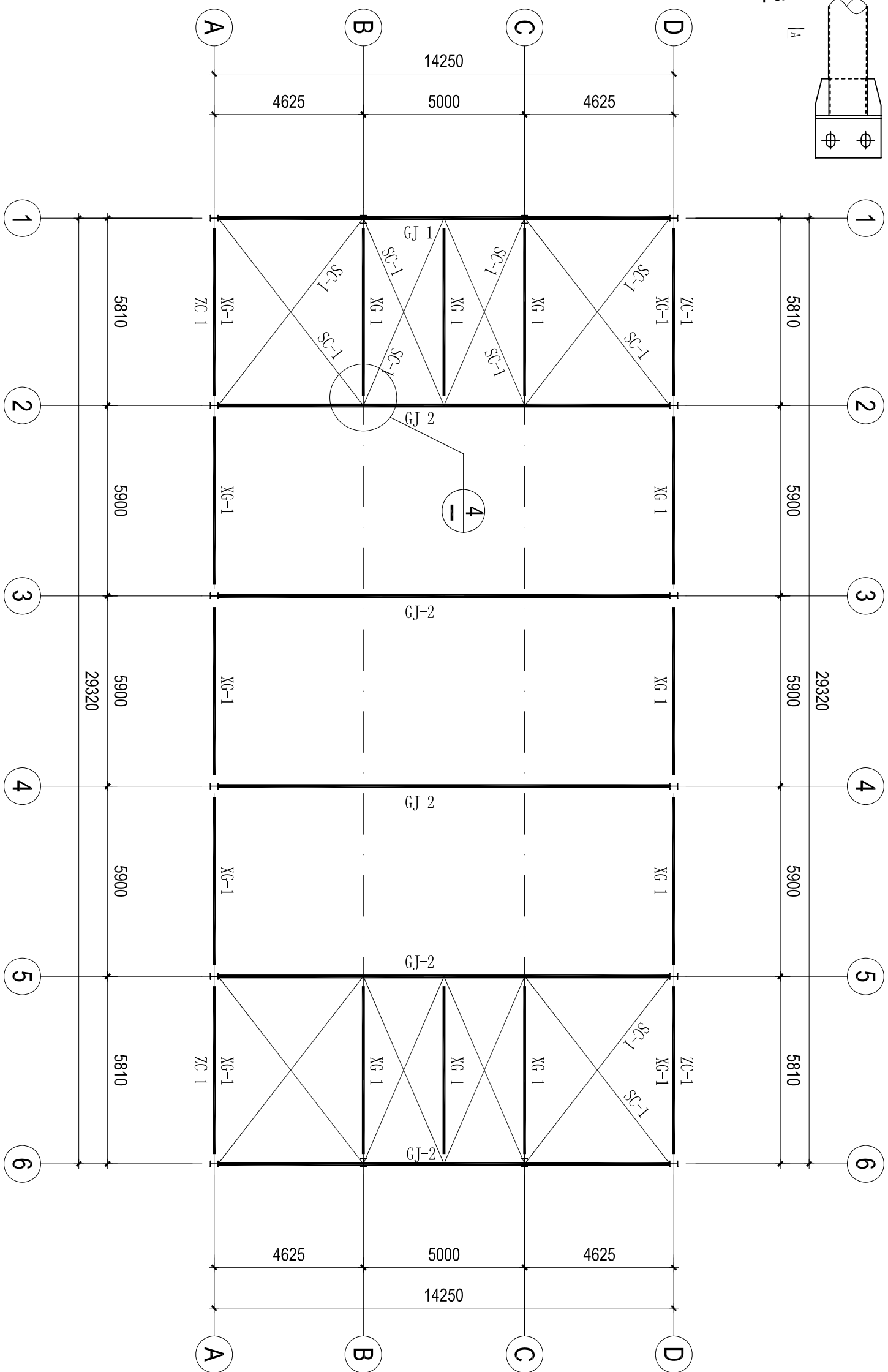

Layout for roof steel structure plan

- XG-1: Ø89*2.5
- SC-1: Ø16 Round steel
- ZC-1: Ø16 Round steel

4

		Hangzhou Putian Steel Structure Co., Ltd	
Item	Layout for roof steel structure plan	Project No.	PTXJW100
Project Name	450m ² project	Category	Proposal
		Page	05
		Version	03
		Date	10.09.28

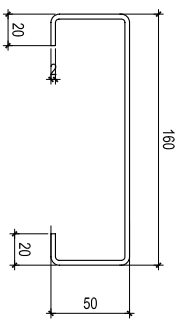

C160*50*20*2.0 截面图 30:1

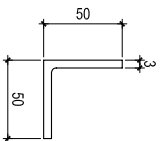

L50*3 截面图 30:1

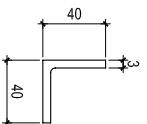

L40*3 截面图 30:1

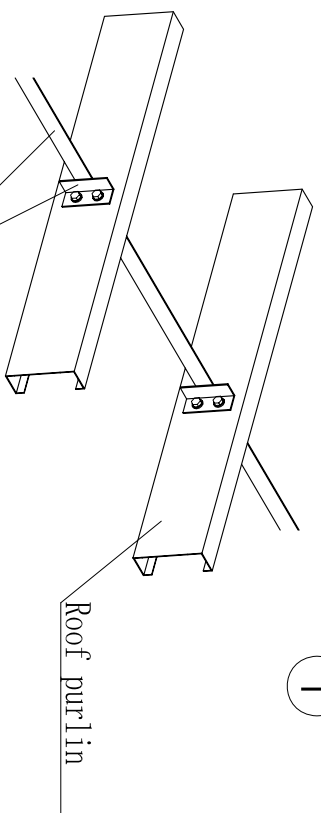
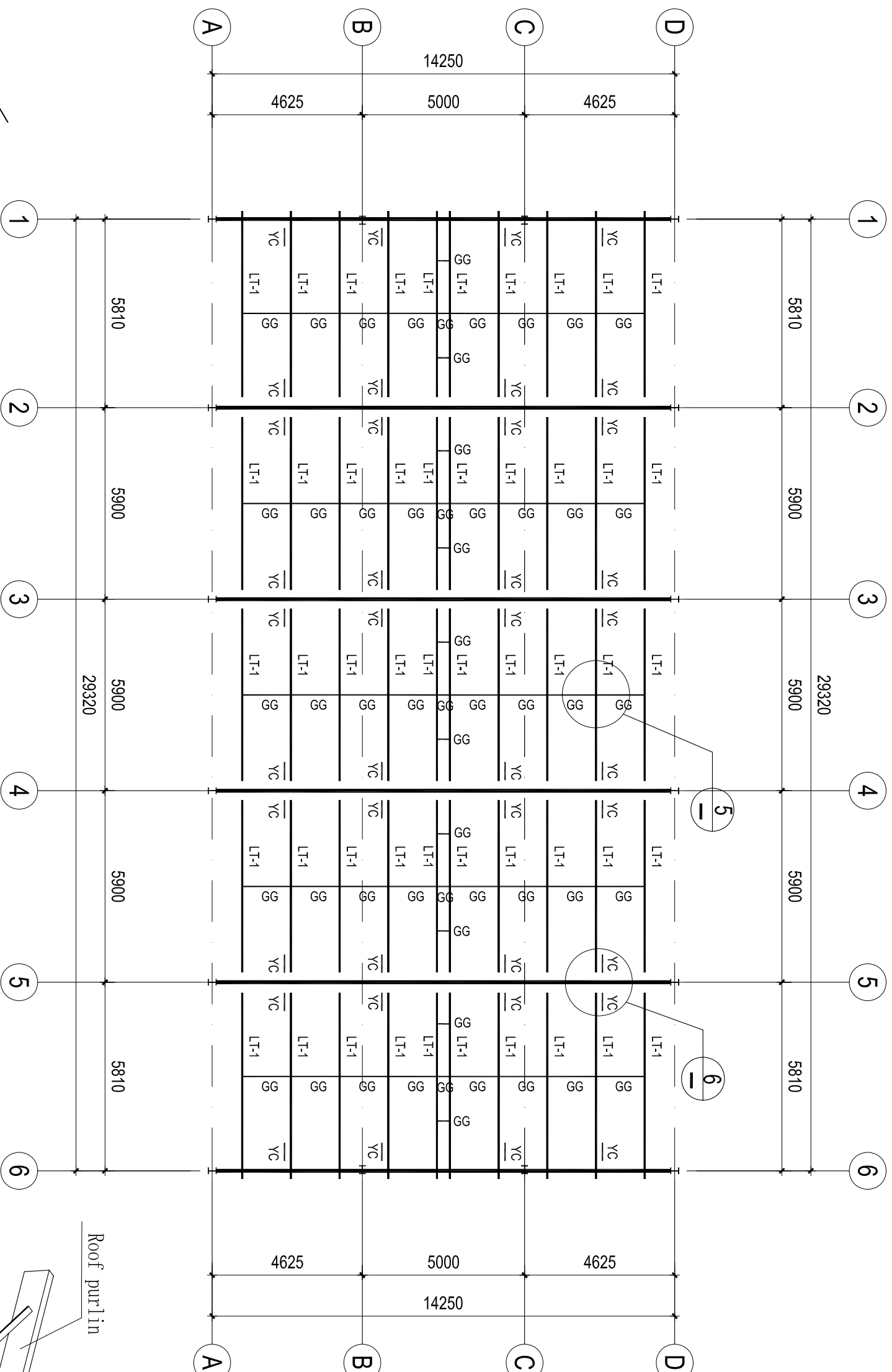

GG:Steel knee-brace
L40*3

5

Layout for roof purlin plan

LT:C160*50*20*2.0 Q345B
YC:L50*3
GG:L40*3

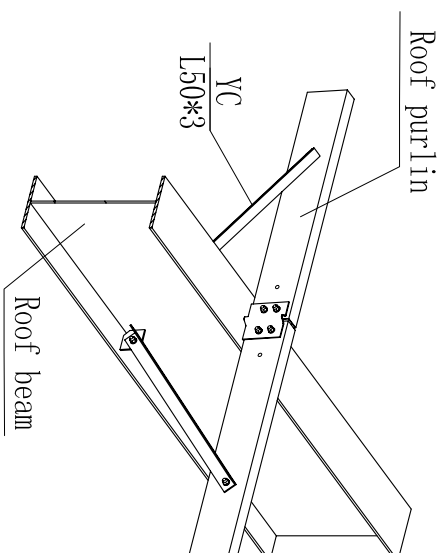

6

Hangzhou Putian Steel Structure Co., Ltd

Item	Layout for roof purlin plan	Project No.	PTX201100	Category	Proposal
Project Name	450m2 project	Version	03	Page	06
比例	200:1	Date	10.09.28		

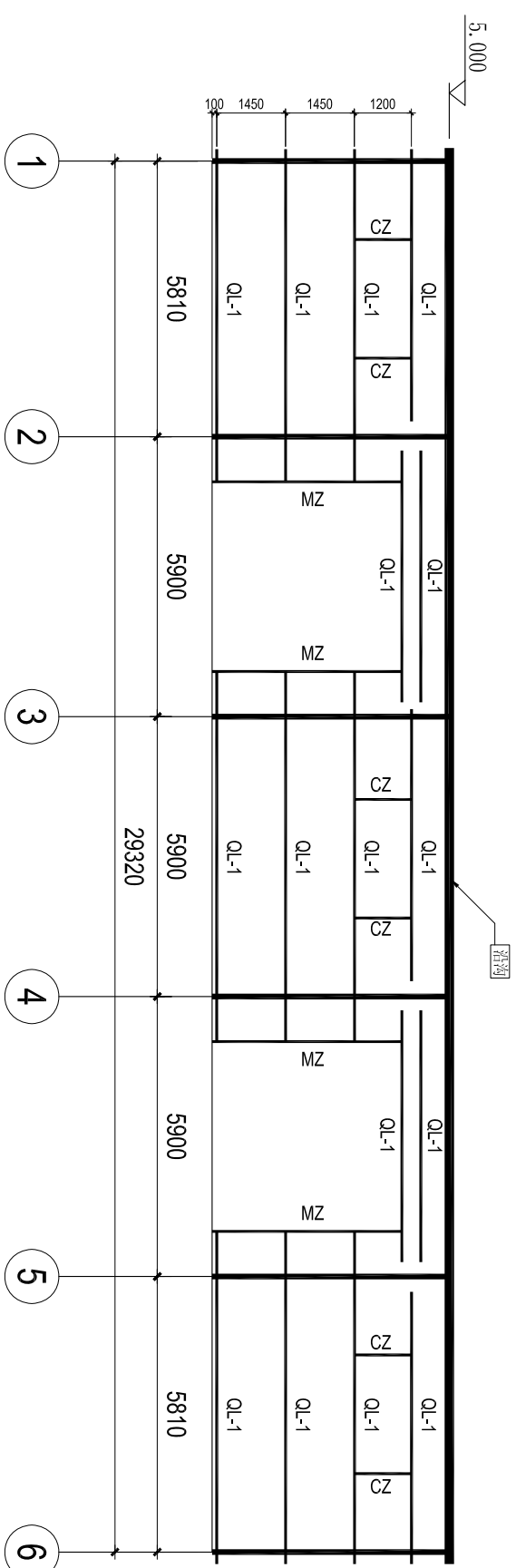

Layout for A axis wall purlin plan

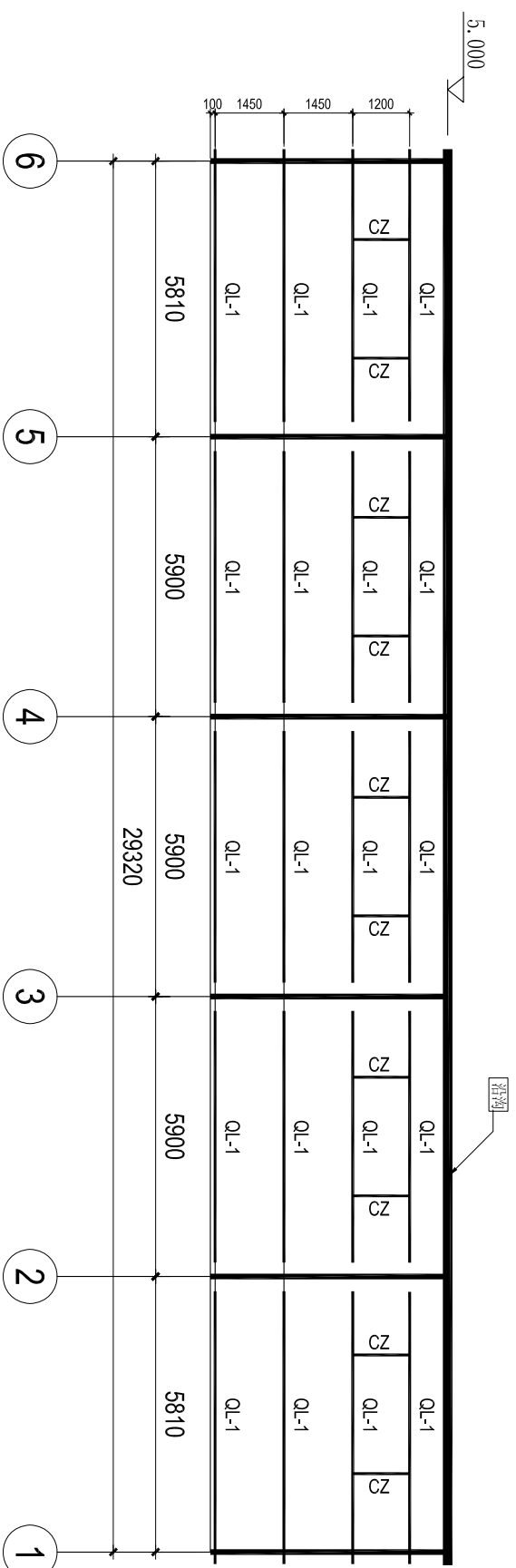

Layout for D axis wall purlin plan

QL-1:C160*50*20*2.0 Q345B
 CZ:C160*50*20*2.0 Q345B
 MZ:C160*50*20*2.0 Q345B

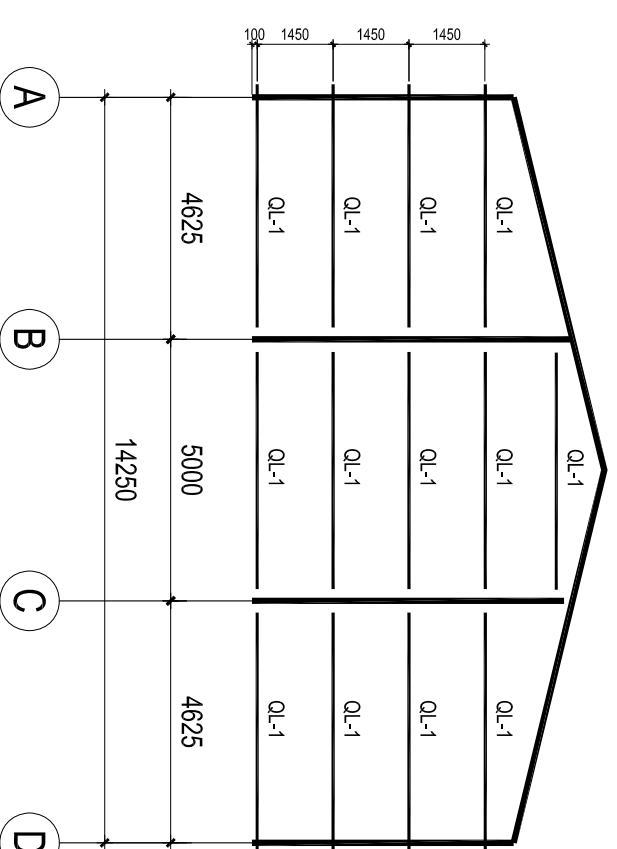

Layout for 1 & 6 axis' wall purlin plan

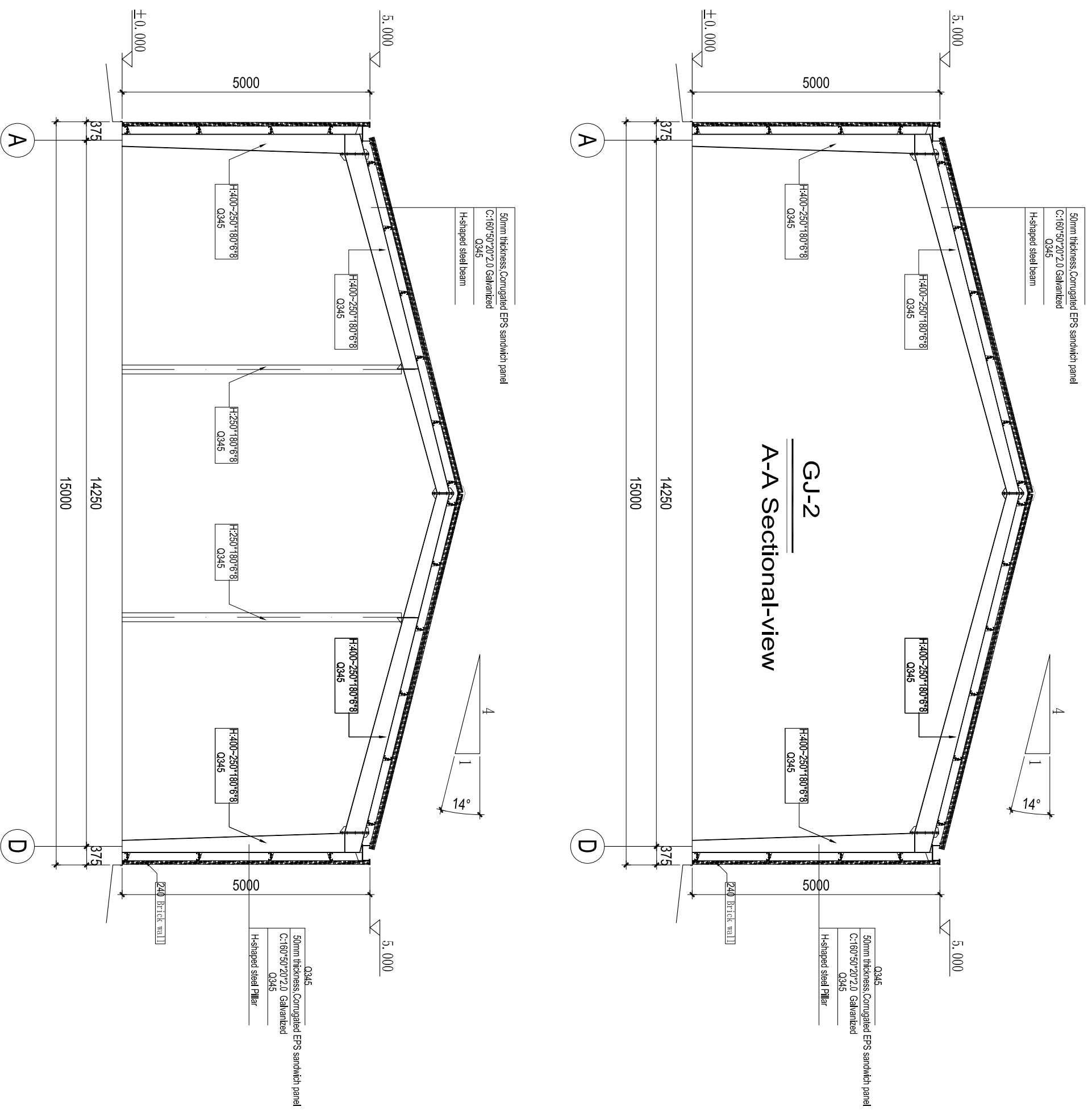

GJ-1

GJ-2
A-A Sectional-view

 Hangzhou Putian Steel Structure Co., Ltd		Item	Steel Frame	Project No.	PT120100	Category	Proposal
		Project Name	450m2 project	Page	08	Version	03
		Scale	1:20:1	Date	10.09.28		